

THE GELERT TRUST

England & Wales · Charity number 1171674

Details

Status Registered

Legal form CIO

Registered 2017-02-17

Register [View on the Charity Commission register](#)

Contact

Address 38 Woodbourne Road
Smethwick
B67 5LZ

Phone 01214291017

Website <https://gelert-trust.org.uk/>

Activities

Objects: 1.TO HOLD AND PRESERVE HISTORIC NARROW GAUGE STEAM LOCOMOTIVES AND RELATED EQUIPMENT, PRIMARILY BUT NOT EXCLUSIVELY THE LOCOMOTIVE ÔGELERTÖ (BAGNALL WORKS NUMBER 3050 OF 1953) FOR THE PUBLIC BENEFIT AND TO ACQUIRE ADDITIONAL SUCH ITEMS.2.TO PRESERVE MAINTAIN OPERATE DISPLAY AND EXHIBIT THE TRUSTÆS ARTEFACTS TO PROMOTE PUBLIC KNOWLEDGE, EDUCATION, APPRECIATION, INTEREST AND UNDERSTANDING OF NARROW GAUGE RAILWAYS, STEAM LOCOMOTIVES AND RELATED EQUIPMENT.3.TO ADVANCE THE EDUCATION OF THE PUBLIC BY PRESERVING AND PROVIDING INSTRUCTION IN THE TRADITIONAL OPERATIONAL AND ENGINEERING SKILLS INVOLVED IN RUNNING AND MAINTAINING IN SERVICE NARROW GAUGE STEAM LOCOMOTIVES AND ANCILLARY EQUIPMENT, AND BY PROVIDING OPPORTUNITIES FOR DIRECT PARTICIPATION IN THOSE ACTIVITIES.

Activities: The Gelert Trust is an educational charity dedicated to preserving and sharing the traditional skills involved in operating and maintaining steam locomotives and associated equipment. It owns steam engine Bagnall No 3050 (?Gelert?), currently resident at Welsh Highland Heritage Railway Porthmadog

Classification

- **How:** Provides Advocacy/advice/information, Other Charitable Activities
- **What:** General Charitable Purposes, Education/training
- **Who:** The General Public/mankind

Geography

- Throughout England And Wales

Finances

Period end	Income	Expenditure	Assets	Employees
2024-12-31	£1,060	£60	-	-
2023-12-31	£1,597	£60	-	-
2022-12-31	£910	£60	-	-
2021-12-31	£880	£0	-	-
2020-12-31	£948	£144	-	-

Trustees

Name	Role	Appointed
ANDREW GOODWIN		2017-02-17
DAVID ALLAN		2017-02-17
GRAHAM FARR		2017-02-17
JOHN KERR		2017-02-17
LEWIS DITTRICH		2017-02-17
MARTYN OWEN		2017-02-17
Mark Seale		2018-01-01
Myles Jones		2021-02-21
NEIL EVANS		2017-02-17
Nigel Watkinson		2017-07-11
Robert Menzies		2022-08-30

THE GELERT TRUST

England & Wales - Charity number 1171674

Accounts

The Gelert Trust – Annual Report 2024

Registered Charity 1171674

38 Woodbourne Road,
Smethwick B67 5LZ

Trustees:

David Allan, Lewis Dittrich, Neil Evans, Graham Farr, Andrew Goodwin, John Kerr, Bob Menzies, Martyn Owen, Nigel Watkinson, Mark Seale, Myles Jones.

Contents

Introduction.....	4
Education and Involvement	5
Engineering and Maintenance.....	6
Funding and Finance	7
Social Media	7
Preserving Gelert's History.....	8
The Future.....	9

Introduction

2024 was another satisfactory year for The Gelert Trust. Gelert's operation at the Welsh Highland Heritage Railway (WHR) has continued, providing opportunities for both training and education, as well as operational experience.

The Trust continues to explore ways of securing Gelert's future, how best to celebrate the locomotive's rich heritage and educate a wider audience about the story of this popular locomotive. The Trust has worked closely with the WHHR to establish a clear partnership in maintaining and celebrating Gelert which has become popular both with volunteers and with visitors to the railway. When not operating or under maintenance Gelert is stored under cover in the Museum of the Welsh Highland Heritage Railway.



Photo –

Education and Involvement

A volunteer has offered support in updating the current website. Commitment from trustees and the volunteers have opened discussions about how best to use this, both for attracting involvement and for education. It is also hoped to develop donation facilities, creating an online shop and other key elements to improve the site. Traffic will be exchanged with the Facebook page when amendments have been made.

During 2024, working parties have continued, both to deal with ongoing routine maintenance, and with ongoing engineering improvements. Work schedules always need to be well communicated to ensure that all Trustees are given the opportunity to offer their support or guidance. Continuing to improve this will be worked on during the 2025 operating season so that new volunteers can be well supported by more experienced Trustees.

The practical use of the engine for operations is always defined by the structure of the WHHR timetable. However, the WHHR has almost exclusively depended on the use of Gelert due to the non-availability of other motive power during 2024, thereby continuing to provide opportunities for training and increasing experience.

There was slight reduction in Gelert's use in normal service, from 40 to 37 days, due to changes in the WHHR timetable, so training opportunities were slightly fewer. However, the training programme was still well maintained, with 9 of the 37 operating days being also training days.

In addition, the programme of footplate experiences and taster sessions continues to be popular. This is particularly important for the Trust, to share knowledge of steam locomotive operation and maintenance with those who may not have memories of such things from their youth.



Photo -

Engineering and Maintenance

Gelert performed well during the 2023 season. However, there was one significant issue that the Trust had to deal with. During the early part of the season Gelert's pony truck leaf spring broke whilst in service. The operating crew at the time dealt with the failure well and the locomotive was safely disposed of and a plan to repair was put together working with the Welsh Highland Railway Ltd. The photos below show the damaged spring:

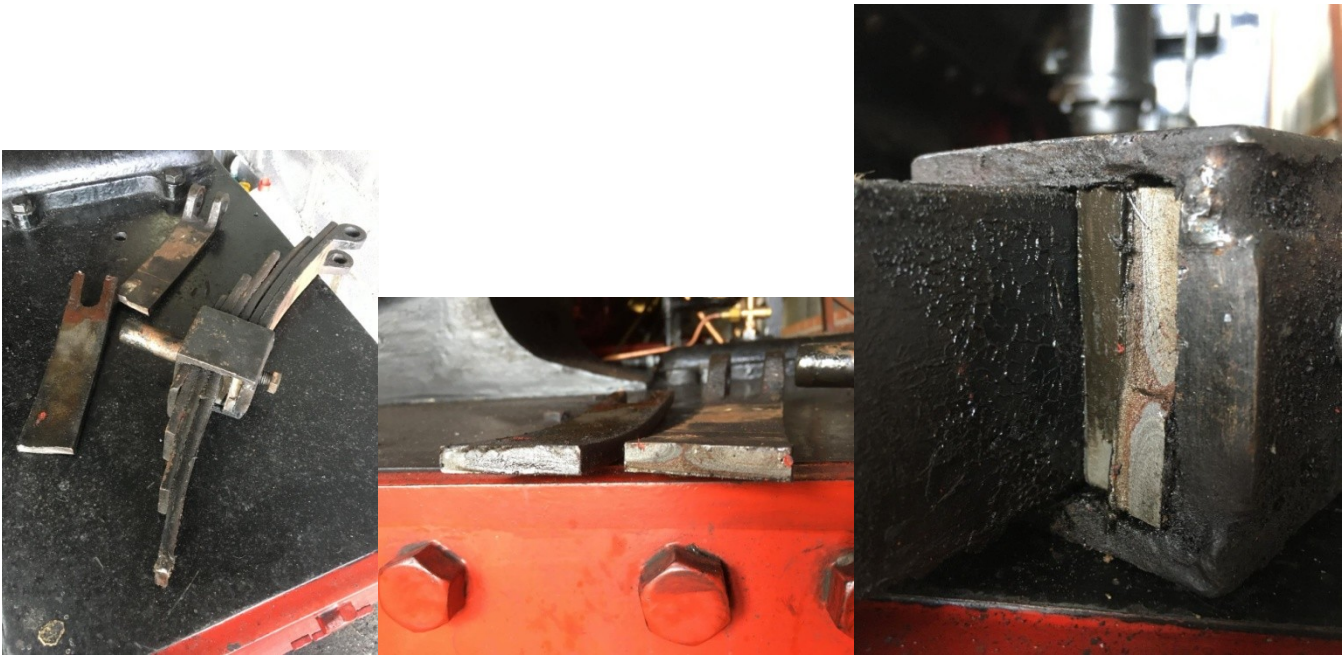

Using drawings from the trust's archives we were able to get new leaves from the spring specially made and have the spring repaired. Along with the repair two spare springs have been made in case of a future failure. The drawing used for the repair came from a collection of drawings made when the locomotive was first restored. Below are the images of the drawing used:

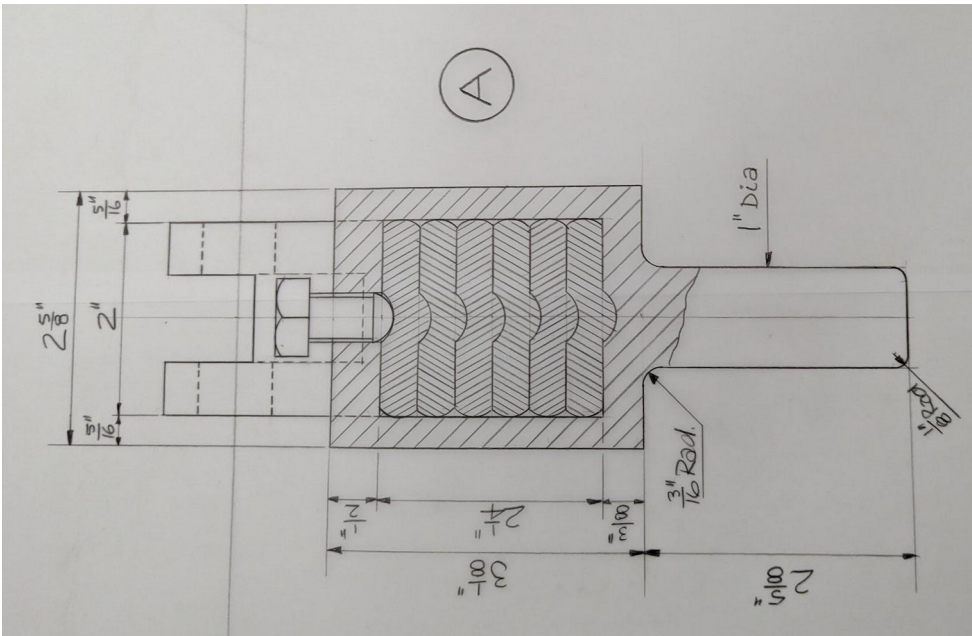
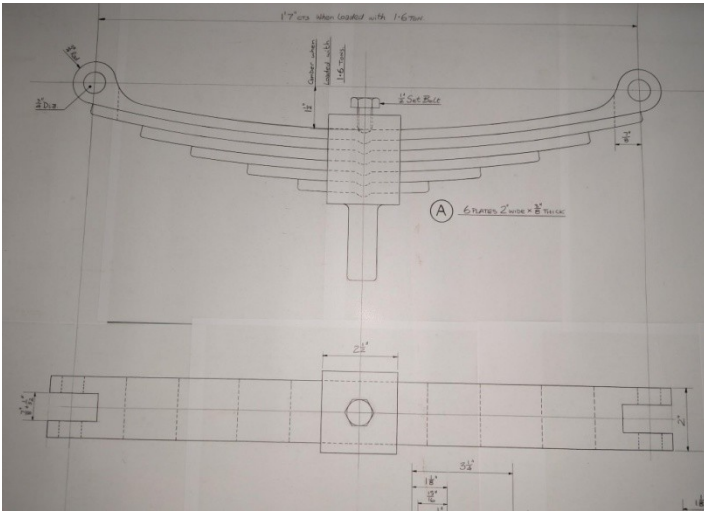

Once completed the new spring was fitted by volunteers in the Welsh Highland Railway Ltd Locomotive Department and included support from trustees, the new spring arrived within a few weeks enabling the locomotive to host a driver experience day. Below are the images of the new spring fitted to the locomotive:



Following the spring replacement the locomotive performed well throughout the season with only regular maintenance performed by the crew operating the loco. During the end of the season the locomotive went through the usual winter maintenance in preparation for the following year.

Funding and Finance

The financial viability of the operation of Gelert remains a key priority for the trust. In 2024 the Trust continued its work with the WHHR to investigate the WHHRs contribution to the locomotive ten-year overhaul, which is now only two years away. The trust believes that the best way to celebrate and educate others about Gelert is through its continued operation in a public environment where adults and children can see, hear, and smell the locomotive, interacting with it and being inspired by an industry of yesteryear, inspiring the community of today. Our work with the WHHR and ensuring there is a financial commitment for Gelert remained a key priority for 2024, alongside seeking to develop a raft of other funding initiatives



Photo -

Social Media

Following from last year the Trust uses a Facebook page as its main media outlet, it is used not only to promote Gelert but also to detail the volunteer work which goes into maintaining and running it. Regular updates have been posted of the winter work and advertising when Gelert has been running on the Welsh Highland Heritage Railway. Included in these updates are means of inquiring about volunteering in any aspects of Gelert at the Welsh Highland Heritage Railway. It attracts a significant and growing audience and engagement, of which the main age groups are 25-34 and 65+. The posts are regularly shared into groups dedicated to Railways such as ours giving us a bigger reach into showing Gelert and its history. The Facebook page has grown with it now having now has 1,812 likes compared to 1,087 likes by the end of 2023.

Facebook is regularly used for organizing volunteer work parties particularly in the wintertime when the major maintenance is undertaken. An email group overlaps with that of the Welsh Highland Heritage Railway and is also used for internal organization of work parties so Gelert can be maintained using the volunteer labour we have most effectively. Discussions continue how to improve promotion of Gelert and The Trust, using both this and the development of the website.

Preserving Gelert’s History

The trust is committed to developing methods of safely storing key documents to the continuing story of Gelert. An online ‘cloud’ system is being used to manage historical archive documents, such as drawing, previous orders, key letters and correspondence and keep current trust documents such as meeting record, financial records, and any current records of the trusts activities, which will then form an historical record in the future.

This will also be used for collecting and preserving information on the history and continuing story of Gelert. It is planned for the website to display much of this information so that it can be available to as wide an audience as possible.

The information boards provided in 2021 to give passengers details of the historical significance of Gelert when not in use and on display continue to be updated with information on Gelert’s history.

The Future

Discussions continue on how to promote Gelert and the Trust, the use of the Facebook page has been a continued success with engagement expanding.

Growing involvement in the work of the Trust is also an ongoing priority. The Trustees will continue to seek to appoint further Trustees in the coming year, both to increase numbers, and particularly to increase participation by younger members.

The trust believes that the best way to celebrate and educate others about Gelert’s history, and the traditional skills involved in operating and maintaining it, is through its continued operation in a public environment where adults and children can see, hear, and smell the locomotive, interacting with it and learning about an industry of yesterday, inspiring the community of today, aided by modern tools where appropriate.

Even after the end of the pandemic, it has continued to be a challenge to engage and encourage new volunteers to work with the trust in the maintenance and development work on Gelert, and recovery is taking some time. However, it is pleasing that progress has continued to be steady during 2024.



Photo -



CHARITY COMMISSION
FOR ENGLAND AND WALES

Charity Name
The GELERT Trust

No (if any)
1171674

CC16a

Receipts and payments accounts

For the period from **01/01/2024** To **31/12/2024**

Section A Receipts and payments

	Unrestricted funds to the nearest £	Restricted funds to the nearest £	Endowment funds to the nearest £	Total funds to the nearest £	Last year to the nearest £
A1 Receipts					
Donations	-	-	-	1,060	950
Gift Aid received	-	-	-	-	630
Gift aid interest	-	-	-	-	17
	-	-	-	-	-
	-	-	-	-	-
	-	-	-	-	-
Sub total (Gross income for AR)	-	-	-	1,060	1,597
A2 Asset and investment sales, (see table).					
	-	-	-	-	-
Sub total	-	-	-	-	-
Total receipts	-	-	-	1,060	1,597
A3 Payments					
Bank charges (Robbery)	60	-	-	60	60
	-	-	-	-	-
	-	-	-	-	-
	-	-	-	-	-
	-	-	-	-	-
	-	-	-	-	-
Sub total	60	-	-	60	60
A4 Asset and investment purchases, (see table)					
	-	-	-	-	-
Sub total	-	-	-	-	-
Total payments	60	-	-	60	60
Net of receipts/(payments)	- 60	-	-	1,000	1,537
A5 Transfers between funds	-	-	-	-	-
A6 Cash funds last year end	-	-	-	-	5,451
Cash funds this year end	60	-	-	6,451	5,451

Section B Statement of assets and liabilities at the end of the period

Categories	Details	Unrestricted funds to nearest £	Restricted funds to nearest £	Endowment funds to nearest £
B1 Cash funds		-	-	-
		-	-	-
		-	-	-
	Total cash funds	6,451	-	-
	(agree balances with receipts and payments account(s))			

	Details	Unrestricted funds to nearest £	Restricted funds to nearest £	Endowment funds to nearest £
B2 Other monetary assets		-	-	-
		-	-	-
		-	-	-
		-	-	-
		-	-	-
		-	-	-

	Details	Fund to which asset belongs	Cost (optional)	Current value (optional)
B3 Investment assets			-	-
			-	-
			-	-
			-	-
			-	-

	Details	Fund to which asset belongs	Cost (optional)	Current value (optional)
B4 Assets retained for the charity's own use			-	-
			-	-
			-	-
			-	-
			-	-
			-	-
			-	-
			-	-
			-	-

	Details	Fund to which liability relates	Amount due (optional)	When due (optional)
B5 Liabilities			-	
			-	
			-	
			-	
			-	

Signed by one or two trustees on behalf of all the trustees

Signature	Print Name	Date of approval
	L C DITTRICH	3/7/25

THE GELERT TRUST

England & Wales - Charity number 1171674

Accounts

The Gelert Trust – Annual Report 2023

Registered Charity 1171674

38 Woodbourne Road,
Smethwick B67 5LZ



Trustees:

David Allan, Lewis Dittrich, Neil Evans, Graham Farr, Andrew Goodwin, John Kerr, David Lampert, Bob Menzies, Martyn Owen, Nigel Watkinson, Mark Seale, Myles Jones, Beth Gloster



Contents

Introduction.....4

Education and Involvement5

Engineering and Maintenance.....6

Funding and Finance7

Social Media7

Preserving Gelert's History.....8

The Future.....9

Introduction

2023 was another satisfactory year for The Gelert Trust. Gelert's operation at the Welsh Highland Heritage Railway (WHR) has continued, providing opportunities for both training and education, as well as operational experience. 2023 was an important year for the trust as this marks Gelert turning 70 years old.

The Trust continues to explore ways of securing Gelert's future, how best to celebrate the locomotive's rich heritage and educate a wider audience about the story of this popular locomotive. The Trust has worked closely with the WHHR to establish a clear partnership in maintaining and celebrating Gelert which has become popular both with volunteers and with visitors to the railway. When not operating or under maintenance Gelert is stored under cover in the Museum of the Welsh Highland Heritage Railway.



Photo – Gelert with volunteers on an evening social



Education and Involvement

A volunteer has offered support in updating the current website. Commitment from trustees and the volunteers have opened discussions about how best to use this, both for attracting involvement and for education. It is also hoped to develop donation facilities, creating an online shop and other key elements to improve the site. Traffic will be exchanged with the Facebook page when amendments have been made.

Whilst coming to the end of the pandemic it was a challenge to engage and encourage new volunteers to work with the trust in the maintenance and development work on Gelert. However, the Trust's work schedule for 2023, and work utilizing both modern CAD and traditional engineering to replace the smoke box floor, were initiatives which have helped to encourage and engage new volunteers to be part of the maintenance and upkeep of this locomotive. The use of social media to share work schedules has been a feature of the trusts work in 2023.

Work schedules always need to be well communicated to ensure that all Trustees are given the opportunity to offer their support or guidance. Continuing to improve this will be worked on during the 2024 operating season so that new volunteers can be well supported by more experienced Trustees.

The practical use of the engine for operations is always defined by the structure of the WHHR timetable. However, the WHHR has increasingly depended on the use of Gelert due to the non-availability of other motive power, thereby increasing opportunities for training and increasing experience. As a result, Gelert was steamed on 51 occasions and provided the service on 40 occasions, crewed by a mix of trustees and other volunteers. Of these, 21 were also training days. In addition, 11 footplate experiences were provided.

Working parties have also continued, to deal both with ongoing routine maintenance, and with continuing engineering improvements.

Engineering and Maintenance

During the 2022 operating season a 'clicking' noise from the right-hand engine/steam chest area had been reported several times. Investigation of this was scheduled to be carried out during the winter by the WHHR locomotive team and Trust volunteers working together. Following Gelert being taken out of service in November 2022, the boiler was washed out and the tanks drained for the winter as usual. A Trust volunteer, assisted by a member of the WHHR locomotive team, removed the steam chest covers for inspection, but after investigation it was concluded that the noise is unlikely to be coming from that area. However, it was also noted that adjustments to valve settings were needed. They were carried out, and all reassembled, including minor repairs to the cover.

The rest of the winter maintenance continued as normal with the boiler being washed out, firebox and smokebox cleaned, gauge glass and other boiler fittings being stripped and dismantled. Much of the winter work involved two young volunteers, who helped with many of the tasks, so it formed a very useful introduction for them to the routine maintenance jobs and work in general on the locomotive.

Following the successful cold boiler examination and steam tests, the work done on the steam chest was assessed, it was confirmed that the clicking noise was not coming from there, but the work on adjusting the valve had been successful as the loco had very clear and clean beats when working. So that work had formed a very interesting and productive learning experience.

However, in addition to that, through a process of elimination and working back from the steam chest the noise reported in the previous operating season was identified to be a very tiny amount of slack in a bearing. This is only a small issue, but will involve a large amount of work to rectify, so it is possible that this work will need to wait until the 10 year overhaul. Again, a very useful and interesting piece of investigative work for the volunteers involved



Photo – Gelert's left hand cylinder cover being removed for inspection

An item previously identified and scheduled for 2023 was the fitting of breathers for the engine's water tanks, these were made by a WHHR volunteer during the pandemic, and these have now been fitted

Funding and Finance

The financial viability of the operation of Gelert remains a key priority for the trust. In 2023 the trust continued its work with the WHHR to investigate the WHHRs contribution to the locomotive ten-year overhaul, which is now only three years away. The trust believes that the best way to celebrate and educate others about Gelert is through its continued operation in a public environment where adults and children can see, hear, and smell the locomotive, interacting with it and being inspired by an industry of yesteryear, inspiring the community of today. Our work with the WHHR and ensuring there is a financial commitment for Gelert remained a key priority for 2023, alongside seeking to develop a raft of other funding initiatives

Social Media

The trust's main social media outlet is currently its Facebook page, used not only to promote Gelert but also to detail the volunteer work which goes into maintaining and running it. Regular updates have been posted of the winter work, and also advertising when Gelert has been running in service on the Welsh Highland Heritage Railway. Included in these updates are means of inquiring about volunteering on any aspects of Gelert.

It attracts a significant and growing audience and engagement, of which the main age groups are 25-34 and 65+. The posts are regularly shared into groups dedicated to Railways such as ours giving us a bigger reach into showing Gelert and its history. The Facebook page now has 1,087 likes with 68.1% of them in the UK followed by 11.1% in the USA.

Facebook is regularly used for organizing volunteer work parties particularly in the wintertime when the major maintenance is undertaken. An email group overlaps with that of the Welsh Highland Heritage Railway and is also used for internal organization of work parties so Gelert can be maintained using available volunteer labour most effectively. Discussions continue how to improve promotion of Gelert and The Trust, using both this and the development of the website.

It is intended to that developments of the Trust's website will include links with the Facebook page so that they can interact with one another. An online shop for memorabilia remains an aspiration to be developed at some point in the future.



Preserving Gelert's History

The trust is committed to developing methods of safely storing key documents to the continuing story of Gelert. An online 'cloud' system is being used to manage historical archive documents, such as drawing, previous orders, key letters and correspondence and keep current trust documents such as meeting record, financial records, and any current records of the trusts activities, which will then form an historical record in the future.

This will also be used for collecting and preserving information on the history and continuing story of Gelert. It is planned for the website to display much of this information so that it can be available to as wide an audience as possible.

The information boards provided in 2021 to give passengers details of the historical significance of Gelert when not in use and on display continue to be updated with information on Gelert's history.

The Future

Discussions continue on how to promote Gelert and the Trust, the use of the Facebook page has been a continued success with engagement expanding.

Growing involvement in the work of the Trust is also an ongoing priority. The Trustees will continue to seek to appoint further Trustees in the coming year, both to increase numbers, and particularly to increase participation by younger members.

The trust believes that the best way to celebrate and educate others about Gelert's history, and the traditional skills involved in operating and maintaining it, is through its continued operation in a public environment where adults and children can see, hear, and smell the locomotive, interacting with it and learning about an industry of yesterday, inspiring the community of today, aided by modern tools where appropriate.

Whilst coming to the end of the pandemic, it was a challenge to engage and encourage new volunteers to work with the trust in the maintenance and development work on Gelert. However, it is pleasing that progress has continued to be steady during 2023



Photo – Gelert at Pen-Y-Mount



CHARITY COMMISSION
FOR ENGLAND AND WALES

Charity Name
The GELERT Trust

No (if any)
177674

CC16a

Receipts and payments accounts

For the period from **01/01/2023** To **31/12/2023**

Section A Receipts and payments

	Unrestricted funds to the nearest £	Restricted funds to the nearest £	Endowment funds to the nearest £	Total funds to the nearest £	Last year to the nearest £
A1 Receipts					
Donations	-	-	-	950	910
Gift Aid received	-	-	-	630	-
Gift aid interest	-	-	-	17	-
	-	-	-	-	-
	-	-	-	-	-
	-	-	-	-	-
	-	-	-	-	-
Sub total (Gross income for AR)	-	-	-	1,597	910
A2 Asset and investment sales, (see table).					
	-	-	-	-	-
	-	-	-	-	-
Sub total	-	-	-	-	-
Total receipts	-	-	-	1,597	910
A3 Payments					
Bank charges (Robbery)	60	-	-	60	-
	-	-	-	-	-
	-	-	-	-	-
	-	-	-	-	-
	-	-	-	-	-
	-	-	-	-	-
	-	-	-	-	-
	-	-	-	-	-
Sub total	60	-	-	60	-
A4 Asset and investment purchases, (see table)					
	-	-	-	-	-
	-	-	-	-	-
Sub total	-	-	-	-	-
Total payments	60	-	-	60	-
Net of receipts/(payments)	- 60	-	-	1,537	910
A5 Transfers between funds	-	-	-	-	-
A6 Cash funds last year end	-	-	-	-	3,914
Cash funds this year end	60	-	-	5,451	3,914

Section B Statement of assets and liabilities at the end of the period

Categories	Details	Unrestricted funds to nearest £	Restricted funds to nearest £	Endowment funds to nearest £
B1 Cash funds		-	-	-
		-	-	-
		-	-	-
	Total cash funds	5,451	-	-

(agree balances with receipts and payments account(s))

	Details	Unrestricted funds to nearest £	Restricted funds to nearest £	Endowment funds to nearest £
B2 Other monetary assets		-	-	-
		-	-	-
		-	-	-
		-	-	-
		-	-	-
		-	-	-

	Details	Fund to which asset belongs	Cost (optional)	Current value (optional)
B3 Investment assets			-	-
			-	-
			-	-
			-	-
			-	-

	Details	Fund to which asset belongs	Cost (optional)	Current value (optional)
B4 Assets retained for the charity's own use			-	-
			-	-
			-	-
			-	-
			-	-
			-	-
			-	-
			-	-
			-	-

	Details	Fund to which liability relates	Amount due (optional)	When due (optional)
B5 Liabilities			-	
			-	
			-	
			-	
			-	

Signed by one or two trustees on behalf of all the trustees

Signature	Print Name	Date of approval
	L C DITTRICH	1/8/24

THE GELERT TRUST

England & Wales - Charity number 1171674

Accounts

The Gelert Trust – Annual Report 2022

Registered Charity
1171674

38 Woodbourne Road,
Smethwick B67 5LZ

Trustees:

David Allan, Lewis Dittrich, Neil Evans, Graham Farr, Andrew Goodwin,
John Kerr, David Lampert, Bob Menzies, Martyn Owen, Nigel Watkinson,
Mark Seale, Myles Jones, Beth Gloster

Contents

Introduction.....	4
Preserving Gelert's History.....	5
Education and Involvement	5
Engineering Work.....	6
Funding and Finance	7
Social Media and The Web.....	8
The Future.....	9

Introduction

2022 was a satisfactory year for The Gelert Trust. Whilst recovery from the pandemic in 2021, has been much slower than expected, progress continues to be steady. Gelert's continued operation at the Welsh Highland Heritage Railway (WHR) has continued, providing opportunities for both training and education, as well as operational experience.

The Trust continues to explore ways of securing Gelert's future, how best to celebrate the locomotive's rich heritage and educate a wider audience to the story of this popular locomotive. The Trust has worked closely with the WHHR to establish a clear partnership in maintaining and celebrating Gelert which has become popular both with volunteers and with visitors to the railway. When not operating or under maintenance Gelert is stored under cover in the Museum of the Welsh Highland Heritage Railway.



Gelert having smokebox work carried out. (photo: Myles Jones)

Preserving Gelert's History

The trust is committed to developing methods of safely storing key documents relating to the Trust's activities. An online 'cloud' system continues to be developed to manage historical archive documents, such as drawings, previous orders, key letters and correspondence and keep current trust documents such as meeting record, financial records, and any current records of the trusts activities to preserve and train in the traditional skills involved in maintaining and using this locomotive. This will then form an historical record in the future.

Most importantly however, this will also be used for collecting and preserving information on the history and continuing story of Gelert. It is planned for the website to display much of this information so that it can be available to as wide an audience as possible.

In addition, work has begun on a booklet outlining Gelert's history and the work of The Trust. Work on this will continue through 2023.

Lastly, information boards provided in 2021 to give passengers details of the historical significance of Gelert when not in use and on display continue to be updated with information on Gelert's history.

Education and Involvement

Expanding involvement in the work of The Trust is an ongoing priority, although the pandemic did severely restricted this, and recovering from its effects has taken longer than expected, and are likely to be felt for some time yet. Nevertheless, it has been possible to continue to involve new and existing volunteers in both operating and maintenance, albeit fewer than would ideally have been the case.

Likewise, the practical use of the engine for operations has been constrained by the limitations of the WHHR timetable, thereby limiting operating training opportunities. Nevertheless the engine was used on 19 occasions during the year, crewed by a mix of trustees, other volunteers, and trainees.

In addition, a series of working parties has continued, both to deal with ongoing routine maintenance, and with the engineering improvements which were begun in 2021 and continued through 2022.



Gelert with volunteers on an evening social (Photo Nigel Watkinson)

Work schedules always need to be well communicated to ensure that all Trustees are given the opportunity to offer their support or guidance. Continuing to improve this will be worked on during the 2023 operating season so that new volunteers can be supported by more experienced Trustees.

The Trustees continue to seek further Trustees and supporters, both to increase involvement, and particularly to encourage participation by younger members. It is pleasing therefore to have been able to appoint a new trustee during 2022

Engineering Work

With volunteer access to Gelert and to on-site facilities now improved post pandemic, more maintenance has been undertaken. The condition of the anodes fitted in 2021 has been carefully monitored and they have reduced the rate that the water tanks corrode, preserving them and significantly extending their lifespan. Other work which has been undertaken is the completion of the work to replace the smokebox floor and baffle plate which had been started in 2021. Both were life expired, so an improved design had been drawn using Computer Aided Design (CAD) so these could be fitted with relative ease.

Another improvement planned for the future is the fitting of “breathers” which allows air into the tanks so the injectors work more efficiently, these being made by a volunteer ready for fitting when volunteer time allows. The locomotive was made ready for steam inspection in March 2022, Gelert passing this test with flying colours and allowing it to run again for the 2022 season.



Gelert's new smokebox floor (left) and baffle plate (right) being made and fitted by our trustees and volunteers. (photos: Myles Jones)

Funding and Finance

The financial viability of the operation of Gelert remains a key priority for The Trust. In 2022 The Trust continued its work with the WHHR to investigate the WHHR's contribution to the locomotive's ten-year overhaul, which is now only four years away.

The Trust believes that the best way to celebrate and educate others about the history of Gelert is through its continued operation in a public environment where adults and children can see, hear and smell the

locomotive, interacting with it and being both inspired by an industry of yesteryear, and inspiring the community of today. Our work with the WHHR to ensure there is a financial commitment towards Gelert's continued maintenance remains a key priority for 2023, alongside seeking to develop a raft of other fundraising initiatives.

Social Media and The Web

The trust's main social media outlet is currently a Facebook page, used not only to promote Gelert but also to detail the volunteer work which goes into maintaining and running it. Regular updates have been posted of the winter work and advertising when Gelert has been running on the Welsh Highland Heritage Railway. Included in these updates are means of inquiring about volunteering in any aspects of Gelert at the Welsh Highland Heritage Railway. It attracts a significant and growing audience and engagement, of which the main age groups are 25-34 and 65+. The posts are regularly shared into groups dedicated to Railways such as ours giving us a bigger reach into showing Gelert and its history.

Facebook is regularly used for organizing volunteer work parties particularly in the wintertime when the major maintenance is undertaken. An email group overlaps with that of the Welsh Highland Heritage Railway and is also used for internal organization of work parties so Gelert can be maintained using the volunteer labour we have most effectively. Discussions continue on how to improve promotion of Gelert and The Trust, using both this and the development of the website.

A volunteer has agreed to provide support in updating the current website. Commitment from Trustees and the volunteers have opened discussions about how to best use this, both for attracting involvement and also for fundraising, and a number of ideas have been generated which have been pursued in 2022, and work has been carried out on developing a specification for what is required. It is intended to that this will include links between the Facebook page and website so that they can interact with one another. An online shop for memorabilia remains an aspiration to be developed at some point in the future. Further work on this is a key priority for 2023.



An early start. (Photo Nigel Watkinson)

The Future

Expanding involvement in the work of the Trust is an ongoing priority. The Trustees will look to appoint further Trustees in the coming year, both to increase numbers, and particularly to increase participation by younger members.

The trust believes that the best way to celebrate and educate others about Gelert's history, the traditional skills involved in operating and maintaining it, is through its continued operation in a public environment where adults and children can see, hear, and smell the locomotive, interacting with it and learning about an industry of yesterday, inspiring the community of today, aided by modern tools where appropriate

Whilst coming to the end of the pandemic, it has been a challenge in 2022 to engage and encourage new volunteers to work with the trust in the maintenance and development work on Gelert. However, progress has been steady, and it is intended to build on that in 2023.



Gelert being warmed up for a day's work (Photo Nigel Watkinson)



CHARITY COMMISSION
FOR ENGLAND AND WALES

Charity Name The GELERT Trust	NO (if any) 1171671
---	------------------------

Receipts and payments accounts

CC16a

For the period from	Period start date 01/01/2022	To	Period end date 31/12/2022
------------------------	---------------------------------	----	-------------------------------

Section A Receipts and payments

	Unrestricted funds to the nearest £	Restricted funds to the nearest £	Endowment funds to the nearest £	Total funds to the nearest £	Last year to the nearest £
A1 Receipts					
Dontions	-	-	-	910	880
	-	-	-	-	-
	-	-	-	-	-
	-	-	-	-	-
	-	-	-	-	-
	-	-	-	-	-
Sub total (Gross income for AR)	-	-	-	910	880
A2 Asset and investment sales, (see table).					
	-	-	-	-	-
Sub total	-	-	-	-	-
Total receipts	-	-	-	910	880
A3 Payments					
Bank charges (Robbery)	60	-	-	60	-
	-	-	-	-	-
	-	-	-	-	-
	-	-	-	-	-
	-	-	-	-	-
	-	-	-	-	-
	-	-	-	-	-
Sub total	60	-	-	60	-
A4 Asset and investment purchases, (see table)					
	-	-	-	-	-
Sub total	-	-	-	-	-
Total payments	60	-	-	60	-
Net of receipts/(payments)	- 60	-	-	850	880
A5 Transfers between funds	-	-	-	-	-
A6 Cash funds last year end	-	-	-	-	3,064
Cash funds this year end	- 60	-	-	3,914	3,064

Section B Statement of assets and liabilities at the end of the period

Categories	Details	Unrestricted funds to nearest £	Restricted funds to nearest £	Endowment funds to nearest £
B1 Cash funds		-	-	-
		-	-	-
		-	-	-
	Total cash funds	3,914	-	-
	(agree balances with receipts and payments account(s))			

Categories	Details	Unrestricted funds to nearest £	Restricted funds to nearest £	Endowment funds to nearest £
B2 Other monetary assets		-	-	-
		-	-	-
		-	-	-
		-	-	-
		-	-	-
		-	-	-

Categories	Details	Fund to which asset belongs	Cost (optional)	Current value (optional)
B3 Investment assets			-	-
			-	-
			-	-
			-	-
			-	-

Categories	Details	Fund to which asset belongs	Cost (optional)	Current value (optional)
B4 Assets retained for the charity's own use			-	-
			-	-
			-	-
			-	-
			-	-
			-	-
			-	-
			-	-
			-	-

Categories	Details	Fund to which liability relates	Amount due (optional)	When due (optional)
B5 Liabilities			-	
			-	
			-	
			-	
			-	

Signed by one or two trustees on behalf of all the trustees

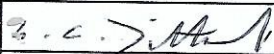
Signature	Print Name	Date of approval
	L C DITTRICH	8/9/23

THE GELERT TRUST

England & Wales - Charity number 1171674

Accounts

The Gelert Trust – Annual Report 2021

Registered Charity 1171674

38 Woodbourne Road,
Smethwick B67 5LZ

Trustees:

David Allan, Lewis Dittrich, Neil Evans, Graham Farr, Andrew Goodwin, John Kerr, David Lampert, Martyn Owen, Nigel Watkinson, Mark Seale, Myles Jones, Beth Gloster

Contents

Introduction.....	4
Maintenance & Display	5
Preserving Gelert's History.....	5
Funding and Finance.....	6
Digital Developments.....	6
Growing Involvement.....	6
The Future.....	7

Introduction

2021 was a quiet year for The Gelert Trust. Gelert's operation at the Welsh Highland Heritage Railway (WHR) continued, but due to the ongoing pandemic, and the limited service on the WHHR, it was only possible to steam Gelert on 15 occasions during the year. During this time 14 individuals crewed the engine, but it was also possible to give operational experience and training to 3 trainees.

The Trust has been spending time considering Gelert's future and how best to celebrate the locomotive's rich heritage and educate a wider audience to the story of this popular locomotive. The Trust has worked closely with the WHHR to establish a clear partnership in maintaining and celebrating Gelert which has become popular both with volunteers and visitors to the railway. When not operating or under maintenance Gelert is stored under cover in the Museum of the Welsh Highland Heritage Railway.



Gelert having smokebox work carried out. (photo: Myles Jones)

Maintenance & Display

With the pandemic restricting volunteer access to Gelert, the core focus of the maintenance was on the completion of earlier projects. The anodes associated with the cathodic protection system have been fitted, the tanks cleaned, and lids replaced. Both injectors have been removed, descaled in an acid mix, inspected, cleaned, and refitted to the locomotive. The locomotive was made ready for the steam inspection in March 2021. However, operations at the WHHR only re-commenced in August 2021 and Gelert was then brought back into regular use for all to see. Information boards were provided to give passengers details of the historical significance of Gelert when not in use and on display.



Gelert's new smokebox floor (left) and baffle plate (right) being made and fitted by our trustees and volunteers. (photos: Myles Jones)

Preserving Gelert's History

The trust is committed to developing methods of safely storing key documents to preserving the history and story of Gelert. An online 'cloud' system is being developed to manage historical archive documents, such as drawing, previous orders, key letters and correspondence and keep current Trust documents such as meeting record, financial records, and any current records of The Trust's activities.

Funding and Finance

The financial viability of the operation of Gelert remains a key priority for The Trust. In 2021 The Trust continued its work with the WHHR to investigate the WHHR's contribution to the locomotive's ten-year overhaul, which is now only five years away. The Trust believes that the best way to celebrate and educate others about the history of Gelert is through its continued operation in a public environment where adults and children can see, hear and smell the locomotive, interacting with it and being both inspired by an industry of yesteryear, and inspiring the community of today. Our work with the WHHR to ensure there is a financial commitment for Gelert remains a key priority for 2022, alongside seeking to develop a raft of other fundraising initiatives.

Digital Developments

The use of the Facebook page has been a continued success with engagement expanding. However, discussions continue on how to improve promotion of Gelert and The Trust, using both this and the development of the website.

A volunteer has agreed to provide support in updating the current website. Commitment from Trustees and the volunteers have opened discussions about how to best use this both for attracting involvement and also for fundraising, and a number of ideas have been generated which will be pursued in 2022 and beyond. It is intended that this will include links between the Facebook page and website so that they can interact with one another. An online shop for memorabilia remains an aspiration to be developed at some point in the future.

Growing Involvement

Expanding involvement in the work of The Trust is an ongoing priority, although the pandemic has necessarily severely restricted this, and its effects are likely to be felt for some time. Nevertheless, it has been possible to continue to involve new and existing volunteers in both operating and maintenance, albeit fewer than would otherwise have been possible.

The Trustees continue to seek further Trustees and supporters, both to increase involvement, and particularly to encourage participation by younger members. It is pleasing therefore to have been able to appoint 2 new trustees during 2021; Myles Jones has both digital and mechanical expertise, and Beth Gloster has taken a role in the financial management of The Trust.

The Future

Whilst coming to the end of the pandemic it has been a challenge in 2021 to engage and encourage new volunteers to work with The Trust in the maintenance and development work on Gelert. However, The Trust has a work schedule planned for 2022 it is hoped to encourage and engage new volunteers to be part of the maintenance and upkeep of this locomotive by utilizing a combination of modern CAD manufacturing and traditional engineering, for example in replacing the smoke box floor. The use of social media to share work schedules has been a feature of The Trust's work in 2021.

Work schedules always need to be well communicated to ensure that all Trustees are given the opportunity to offer their support or guidance. Continuing to improve this will be worked on during the 2022 operating season so that new volunteers can be better supported by more experienced Trustees.



Gelert with the WHHR's heritage carriages before a day's work. (photo: Myles Jones)



Charity Name
The GELERT Trust

No (if any)
1171674

CC16a

Receipts and payments accounts

For the period from 01/01/2021 To 31/12/2021

Section A Receipts and payments

	Unrestricted funds to the nearest £	Restricted funds to the nearest £	Endowment funds to the nearest £	Total funds to the nearest £	Last year to the nearest £
A1 Receipts					
Dontions	-	-	-	880	1,092
	-	-	-	-	-
	-	-	-	-	-
	-	-	-	-	-
	-	-	-	-	-
	-	-	-	-	-
Sub total (Gross income for AR)	-	-	-	880	1,092
A2 Asset and investment sales, (see table).					
	-	-	-	-	-
Sub total	-	-	-	-	-
Total receipts	-	-	-	880	1,092
A3 Payments					
	-	-	-	-	-
	-	-	-	-	-
	-	-	-	-	-
	-	-	-	-	-
	-	-	-	-	-
	-	-	-	-	-
Sub total	-	-	-	-	-
A4 Asset and investment purchases, (see table)					
	-	-	-	-	-
Sub total	-	-	-	-	-
Total payments	-	-	-	-	-
Net of receipts/(payments)	-	-	-	880	1,092
A5 Transfers between funds	-	-	-	-	-
A6 Cash funds last year end	-	-	-	-	2,184
Cash funds this year end	-	-	-	3,064	2,184

Section B Statement of assets and liabilities at the end of the period

Categories	Details	Unrestricted funds to nearest £	Restricted funds to nearest £	Endowment funds to nearest £
B1 Cash funds		-	-	-
		-	-	-
		-	-	-
	Total cash funds	3,064	-	-
	(agree balances with receipts and payments account(s))			



Categories	Details	Unrestricted funds to nearest £	Restricted funds to nearest £	Endowment funds to nearest £
B2 Other monetary assets		-	-	-
		-	-	-
		-	-	-
		-	-	-
		-	-	-
		-	-	-

Categories	Details	Fund to which asset belongs	Cost (optional)	Current value (optional)
B3 Investment assets			-	-
			-	-
			-	-
			-	-
			-	-

Categories	Details	Fund to which asset belongs	Cost (optional)	Current value (optional)
B4 Assets retained for the charity's own use			-	-
			-	-
			-	-
			-	-
			-	-
			-	-
			-	-
			-	-

Categories	Details	Fund to which liability relates	Amount due (optional)	When due (optional)
B5 Liabilities			-	
			-	
			-	
			-	
			-	

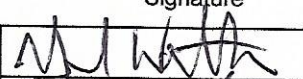
Signed by one or two trustees on behalf of all the trustees

Signature	Print Name	Date of approval
	N. WARKINS	
	A.C. DITTUS	

THE GELERT TRUST

England & Wales - Charity number 1171674

Accounts

The Gelert Trust – Annual Report 2020

Registered Charity 1171674

38 Woodbourne Road,
Smethwick B67 5LZ

Trustees:

David Allan, Lewis Dittrich, Neil Evans, Graham Farr, Andrew Goodwin, John Kerr, David Lampert, Martyn Owen, Nigel Watkinson, Mark Seale, Anthony McLachlan

Contents

Introduction.....	4
Maintenance & Display	5
Website and Communications.....	6
The Future	6

Introduction

2020 was a quiet year for The Gelert Trust. Gelert's continued operation at the Welsh Highland Heritage Railway (WHR) was suspended due to the pandemic in 2020 and as a result, the engine was not used during the year. Late in 2019, Gelert was taken out of service to prepare the locomotive for its annual boiler examination. Shortly after this, the pandemic restrictions were declared and all work on the engine was suspended.

The pandemic restrictions also meant that the usual cycle of Trustee meetings was not possible. However, the Trust's existing online decision making procedures ensured that the management of the Trust could continue smoothly, although it was necessary to hold an EGM remotely to consider urgent issues in place of the usual physical AGM.

In May 2020 Trustee Anthony McLachlan passed away suddenly; this was totally unexpected and a shock to the remaining Trustees. Anthony managed the Trust website on behalf of the Trust so the remaining Trustees are monitoring the issue and are looking at alternative arrangements for managing the website with an alternative supplier.

The Trust has been spending time considering the future of Gelert and how best to celebrate the locomotive's rich heritage and educate a wider audience to the story of this popular locomotive. The Trust has worked closely with the WHHR to establish a clear partnership in maintaining and celebrating Gelert which has become a popular locomotive with WHHR volunteers and visitors to the railway. Gelert is currently stored under cover in the Museum of the Welsh Highland Heritage Railway.



Photo - Gelert's cab controls - let us hope that soon volunteers can be polishing and cleaning these controls whilst operating Gelert during the 2021 season. *(Photo by M Seale)*



Photo - Gelert Trustee and Training Officer for WHHR, Lewis Dittrich, on a driver's training day.
(Photo by Jane Partridge)

Maintenance & Display

With the pandemic restricting volunteer access to Gelert, the main focus of the maintenance was on the completion of earlier projects. The anodes associated with the cathodic protection system have been fitted, the tanks cleaned and lids replaced. Both injectors have been removed, descaled in an acid mix, inspected, cleaned and refitted to the locomotive. The locomotive was made ready for the steam inspection in March 2020. However, all access to the locomotive was paused during the first wave of the pandemic to ensure the safety of all volunteers and Trustees. However, operations at the WHHR re-commenced in August 2020 and Gelert was placed on display in the Museum/Heritage Centre for all passengers to see. Information boards were provided to give passengers details of the historical significance of Gelert.



Photo - Gelert on display at the Museum/Heritage Centre at the WHHR during the summer of 2020. (Photo by M Seale)

Website and Communications

The development of the website has been a priority of the Trust since its formation. Following a variety of inputs, a plan had been developed and basic work done. A number of elements were being trialed when the Trust's webmaster suddenly died. Following that, not only did that initiative stop, but temporary measures needed to be hurriedly put in place to keep the existing facility live. Alongside that, options needed to be explored to put more permanent arrangements in place. Also, a new plan needed to be generated for the development of the Trust's online presence. Some preliminary work has been done on this aspect. It is a major priority for 2021.

The website is seen as a key element of the Trust's reach. It is vital for communication, for publicising the Trust's work, and not least as a potential fundraising tool. Improved links with its other online exposures, such as its Facebook page, are other important parts of this. Work on it will continue to be a priority.

The Future

It is hoped to begin developing an online system to store important Trust documents safely. This would not only be a valuable management tool for the Trust, but more importantly an historical archive of Gelert's activities, both currently and in the past. So, this will be a priority for development in 2021.

To ensure the safe keeping and continued existence of Gelert, the Trust is committed to investing in the future of the locomotive. During 2020, Trustees have engaged with the WHHR to discuss future financial commitments to ensure Gelert's next overhaul in six years' time can

be afforded and that this significant issue is being considered and planned for by the WHR Ltd board.

Work schedules always need to be well communicated to ensure that all Trustees are given the opportunity to offer their support or guidance. Continuing to improve this will be worked on during the 2021 operating season so that new volunteers can be better supported by more experienced Trustees.

Expanding involvement in the work of the Trust is an ongoing priority. The Trustees will look to appoint further Trustees in the coming year, both to increase numbers, and particularly to increase participation by younger members.

The Covid pandemic has introduced much uncertainty into the work of the Trust. Practical work has needed to be put on hold, operation has also ceased (as has much work on the host WHHR). However, planning has continued, and hopefully 2021 will give opportunities to move forward. Once it is safe to do so, working parties will commence on returning Gelert to service.



CHARITY COMMISSION
FOR ENGLAND AND WALES

Charity Name
The GELERT Trust

No (if any)

CC16a

Receipts and payments accounts

For the period from	Period start date 01/01/2020	To	Period end date 31/12/2020
---------------------	---------------------------------	----	-------------------------------

Section A Receipts and payments

	Unrestricted funds to the nearest £	Restricted funds to the nearest £	Endowment funds to the nearest £	Total funds to the nearest £	Last year to the nearest £
A1 Receipts					
Dontions	-	-	-	1,092	660
	-	-	-	-	-
	-	-	-	-	-
	-	-	-	-	-
	-	-	-	-	-
	-	-	-	-	-
Sub total (Gross income for AR)	-	-	-	1,092	660
A2 Asset and investment sales, (see table).					
	-	-	-	-	-
Sub total	-	-	-	-	-
Total receipts	-	-	-	1,092	660
A3 Payments					
Web site maintenance fee	-	-	-	144	-
	-	-	-	-	-
	-	-	-	-	-
	-	-	-	-	-
	-	-	-	-	-
	-	-	-	-	-
Sub total	-	-	-	144	-
A4 Asset and investment purchases. (see table)					
	-	-	-	-	-
Sub total	-	-	-	-	-
Total payments	-	-	-	144	-
Net of receipts/(payments)	-	-	-	948	660
A5 Transfers between funds	-	-	-	-	-
A6 Cash funds last year end	-	-	-	-	1,237
Cash funds this year end	-	-	-	2,185	1,237

Section B Statement of assets and liabilities at the end of the period

Categories	Details	Unrestricted funds to nearest £	Restricted funds to nearest £	Endowment funds to nearest £
B1 Cash funds		-	-	-
		-	-	-
		-	-	-
	Total cash funds	2,185	-	-

(agree balances with receipts and payments account(s))

OK OK

Categories	Details	Unrestricted funds to nearest £	Restricted funds to nearest £	Endowment funds to nearest £
B2 Other monetary assets		-	-	-
		-	-	-
		-	-	-
		-	-	-
		-	-	-
		-	-	-

Categories	Details	Fund to which asset belongs	Cost (optional)	Current value (optional)
B3 Investment assets			-	-
			-	-
			-	-
			-	-
			-	-

Categories	Details	Fund to which asset belongs	Cost (optional)	Current value (optional)
B4 Assets retained for the charity's own use			-	-
			-	-
			-	-
			-	-
			-	-
			-	-
			-	-
			-	-

Categories	Details	Fund to which liability relates	Amount due (optional)	When due (optional)
B5 Liabilities			-	
			-	
			-	
			-	
			-	

Signed by one or two trustees on behalf of all the trustees

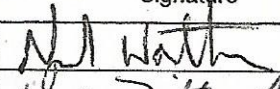
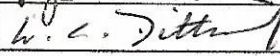
Signature	Print Name	Date of approval
	NIGEL WATKINSON	18/8/21
	LEWIS DITTRICH	18/8/21